



## PECoS Model DB

### Description

The PECoS Model DB is an advanced 32-bit general purpose digital engine controller. This device gives precise governing with an abundant amount of external control features. PG's Flex I/O system allows up to four ports to be dynamically reconfigured as auxiliary outputs, discrete inputs, or analog inputs. This allows the PECoS DB to accommodate a wide range of control systems and to adapt to new requirements. The PECoS DB also includes a CAN bus allowing the controller to communicate using the J-1939 standard protocol.

This robust controller provides an economical means to process analog and switched input signals to control actuators and relays in providing control for various engine setups. The PECoS Model DB is capable of preventing overtemperature, over-current, and over-voltage conditions. The control board is able to self check for faulty sensors or actuators, report faults and correct or compensate for minor faults. The PECoS Model DB is field programmable and provides flexibility for customization and installation.

The following contains all the features and data that are available in this package. PG can customize this controller and its software to fit the needs of your application.

### Features

Engine speed and acceleration control

Auto-Start and shutdown

Overspeed Protection

Fault monitoring and status indication

Variable speed and PTO speed operation

Drive-By-Wire (DBW) using electronic foot pedal or potentiometer

Sealed water proof enclosure and connector

12/24 volt DC power

Reverse polarity protected\*

PID actuator control loop

4 analog

3 digital inputs

4 auxiliary outputs

4 Flex ports which may be configured as analog inputs, digital inputs, or auxiliary outputs

Speed sensor (e.g. magnetic pick-up, ignition...)

Actuator controls

RS-232 communication

CAN communication with J-1939 protocol

5 VDC output for sensor power

## Wiring

Pin No.	Pin Name	Type	Description
J2-A01	CGND	Protection Ground	Chassis ground
J2-B01	FLEX5	Configurable	Flexible reconfigurable I/O port
J2-C01	FLEX6	Configurable	Flexible reconfigurable I/O port
J2-D01	V+5 OUT	Output Supply	5 Volt sensor supply
J2-E01	ANALOG 1	Analog	Analog input
J2-F01	CANH	CAN	CAN bus high port
J2-G01	GOV RET	Governor	Actuator control signal return
J2-H01	GOV PWM	Governor	Actuator control signal output
J2-J01	POWER	Power	DC power to controller
J2-K01	POWER	Power	DC power to controller
J2-A02	AUX 1	Output	Grounding auxiliary output
J2-B02	AUX 2	Output	Grounding auxiliary output
J2-C02	FLEX7	Configurable	Flexible reconfigurable I/O port
J2-D02	ANALOG 2	Analog	Analog input
J2-E02	ANALOG 3	Analog	Analog input
J2-F02	CANL	CAN	CAN bus low port
J2-G02	IN 1	Input	Discrete input battery triggered
J2-H02	IN 2	Input	Discrete input battery triggered
J2-J02	SCI TX	Serial	Serial out RS-232 capable (DB-9 pin 2)
J2-K02	IN 3	Input	Discrete input ground triggered (Fault input)
J2-A03	AUX 3	Output	Grounding auxiliary output
J2-B03	AUX 4	Output	Grounding auxiliary output
J2-C03	FLEX8	Configurable	Flexible reconfigurable I/O port
J2-D03	ANALOG 4	Analog	Analog input
J2-E03	AGND	Ground	Analog signal ground/return
J2-F03	SS+	Speed signal	Engine speed signal out
J2-G03	SS-	Speed signal return	Engine speed signal return
J2-H03	SCI RX	Serial	Serial in RS-232 capable (DB-9 pin 3)
J2-J03	GND	Ground	Controller ground
J2-K03	GND	Ground	Controller ground

## Pin Layout

	A	B	C	D	E	F	G	H	J	K
01	Chassis	FLEX5	FLEX6	V+5 out	ANALOG 1	CANH	GOV RET	GOV PWM	POWER	POWER
02	AUX 1	AUX 2	FLEX7	ANALOG 2	ANALOG 3	CANL	IN1	IN2	SCI TX	IN3
03	AUX 3	AUX 4	FLEX8	ANALOG 4	AGND	SS+	SS-	SCI RX	GND	GND

## Specifications

### **Mechanical**

Operating temp	-40 to 85°C -40 to 185°F
Weight	1lb
Vibration	6 G, 40 to 2000 Hz 8 hours per axis
Sealing	IP65, 66, 67, 69K

### **Inputs**

Power supply	8-30 VDC
Analog Input Range	0-20 VDC (40V max)
Digital	0-Battery VDC
Flex	Same as analog/digital
Speed sensor	+/-100 V AC/DC 0-15 kHz

### **Outputs**

Aux current max	100mA
Flex	Same as aux
5V rail max current	100mA
Governor peak current	6A

### **Communication**

RS-232	57600 baud 8 data bits No parity 1 stop bit No flow control
CAN bus	J-1939 protocol Up to 1M baud Custom commands

## Port Descriptions

**Power (POWER/GND):** 8-30V power input to controller reverse polarity protected.

**5 Volt output (V+5):** 5 volt source for power sensors or other peripherals. Short circuit protected.

**Governor output (GOV RET/PWM):** Pulsed signal output typically used to control an actuator. Software short circuit and overload protected.

**Speed Sensor (SS+/-):** Speed signal input which may be used to measure engine speed from multiple sources such as a magnetic pickup, ignition source, or transformer.

**Auxiliary output (AUX):** Controller output which can be sunk to ground on a given condition or input. Short circuit, overload, and over temperature protected.

**Analog input (ANALOG/AGND):** Analog input which may sense from 0-20 volts. Capable of providing source as well if needed to power certain sensors. Thresholds may be set to trigger certain actions based on readings. Use AGND for reference to analog inputs.

**Digital input (IN):** There are two discrete inputs which may be triggered by battery voltage and one which is triggered by grounding and is typically used as a fault input.

**Flex I/O (FLEX):** The Flex I/O ports may be configured as an auxiliary output, analog input, or digital input. These ports are reconfigurable by software and have the same features as mentioned above.

**CAN (CANH/L):** The CAN bus is used to communicate to other devices on the bus using the J-1939 standard protocol. Custom commands and actions may be added by PG if needed.

**Serial (SCI RX/TX):** Used to interface to a PC or other peripheral. The serial port is typically used to show data coming from the controller and may also be used to reprogram the device in the field.

**\*Reverse Polarity Protection:**

**Auxiliary output / Flex as output:** The flex and auxiliary output devices will activate during application of reverse polarity. If the connected load contains a flyback diode, a series diode is required for reverse polarity protection.

**Flex pins:** When used as analog or discrete inputs: if the flex pins are or may be connected to a +DC power source through less than a 20Ω circuit, the circuit should incorporate a series diode (1 amp such as 1N4001) in series from the power source. It is permissible to use one diode to source protected power to all flex input circuits.

**+5 VDC output:** This should not be connected to a +DC power source through any external components.

**All other pins are fully protected against application of reverse polarity.**

## Calibrations

Parameter	Description
Proportional	Response time
Integral	Steady state error
Derivative	Stability adjustment
Gain	Master gain response
Ramp-up	Engine speed rate of change up
Ramp-down	Engine speed rate of change down
Set speed max	Max settable speed via pot
Set speed min	Min settable speed via pot
Warm-up %	Percent of set speed for engine warm-up
Warm-up time	Warm up time
Pulses per rev	Pulse per engine revolution
Min pulses per update	Pulses till next speed calculation
Overspeed %	Shutdown max speed
Overspeed time	Time till overspeed trips
Underspeed %	Shutdown min speed
Underspeed time	Time till underspeed trips
Underspeed run time	Seconds after start when under speed checked

NOTE: 2 separate calibrations can be saved and loaded



# Wiring

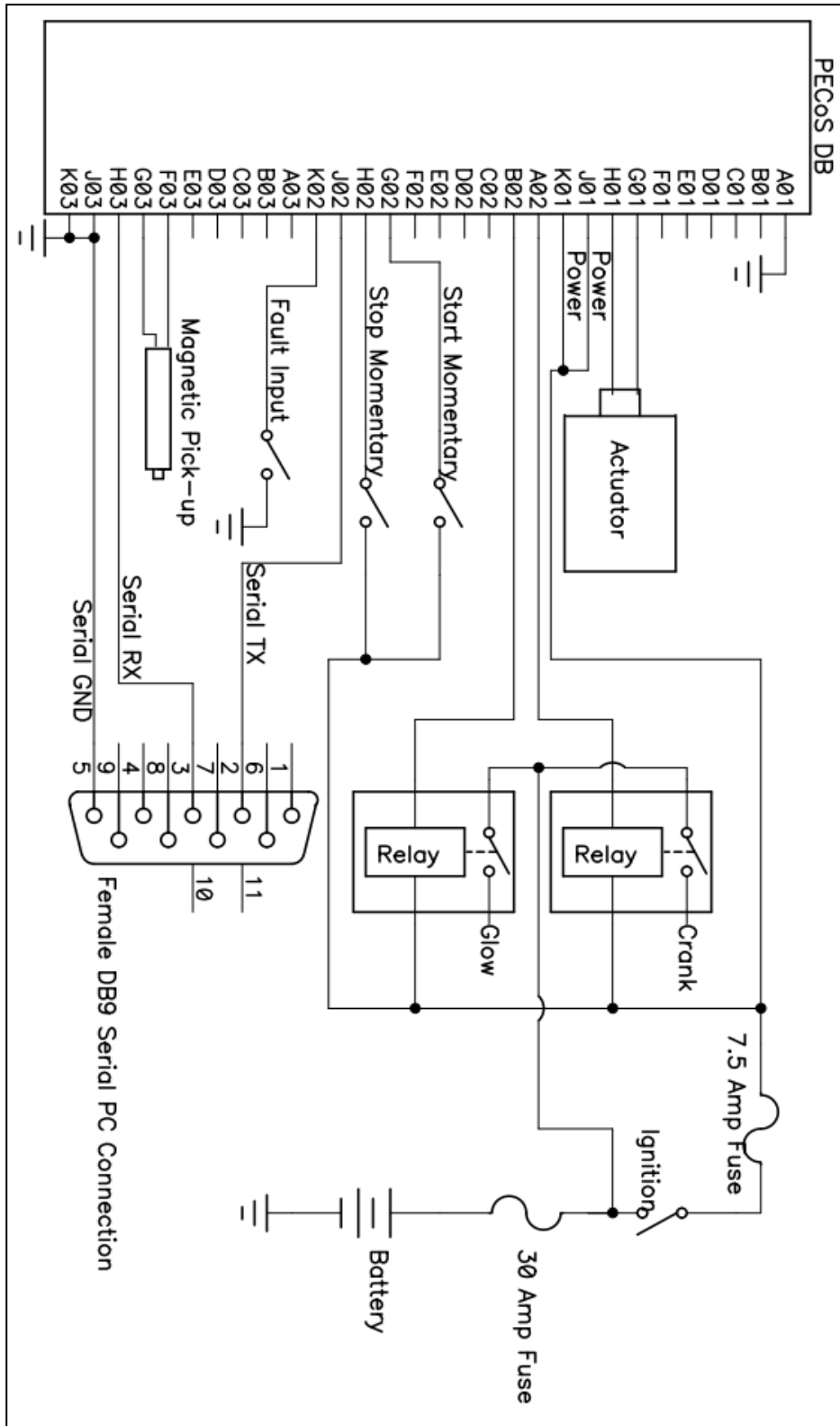

## Dimensions

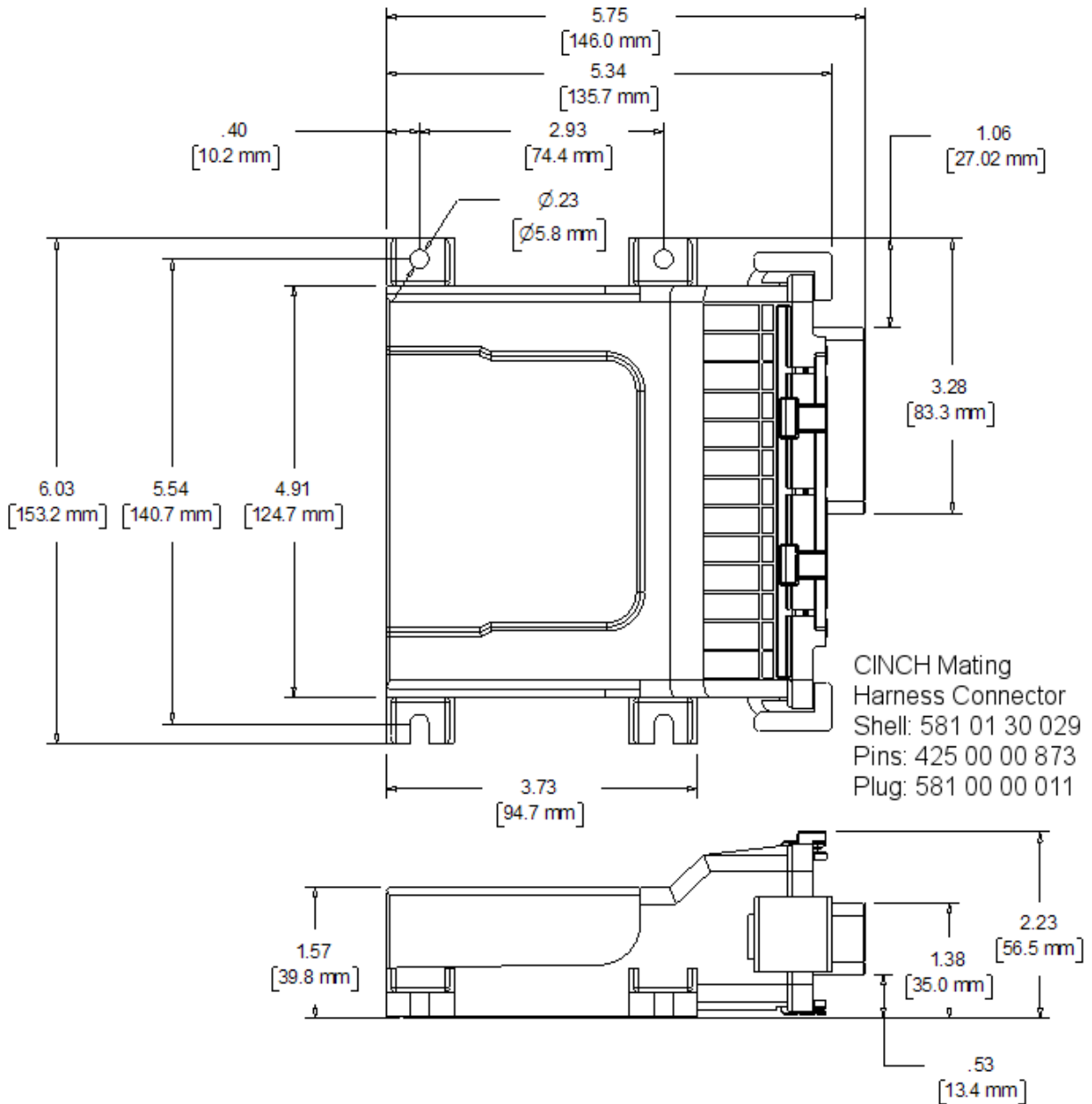

## Reference

PECoS Model DB Part Number	#9705
Cinch Harness Connector	#581 01 30 029
Hand Crimp tools:	
18/16 ga GXL 16 ga TXL	#599-11-11-616
Pins	#425-00-00-873
20 ga GXL / 18 ga TXL	#599-11-11-615
Pins	# 425-00-00-872